

ELS PAR30 9 watt Based LED Lamp Specification and Data Sheet

Electronic Lighting Systems, Inc's LED lamps are the next generation in solid state lighting Technology. Our LED lamps combine highly efficient materials that allow our lamps an efficacy that far exceeds other brands in the marketplace.

Our PAR30 Lamp series is a direct replacement for incandescent and halogen PAR30 lamps. The ELS PAR30 consumes only 9 watts, reducing your energy consumption up to 85% of your current use. Our lamp is a low heat emitting light, which produces No UV or IR, which reduces HVAC loads and temperatures. This feature greatly reduces maintenance costs.

Features:

- High Lumen Output
- High Efficiency and Reliability
- Low Power Consumption
- Over 50,000 hour life span
- UL & CE/RoHs Certificate Compliant
- 3 year Manufacturers Warranty

Applications:

- General Illumination
- Down Lighting
- Architectural Lighting
- Recessed Lighting
- Stage Lighting
- Outdoor Lighting
- Landscaping

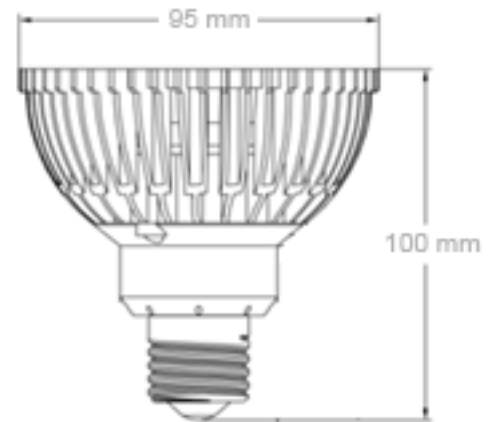

Specification Details

Model No:	ELS-P 30-9-WW	ELS-P 30-9-CW
Input Voltage	AC110-277V 50/60HZ	
Power Consumption	9 watts	
Color	Warm White	Cool White
Luminous Flux	520Lm	615Lm
Lumen Maintenance	70%	
Color Temperature	3000K	5500K
CRI	80	
Operation Temperature	-20°C-45°C	
Base	E26/E27/GU10	
Product Dimensions	Φ5×100mm	
Viewing Angle	15/30/45/60°	
Weight	300g	

Cost of Energy Comparison

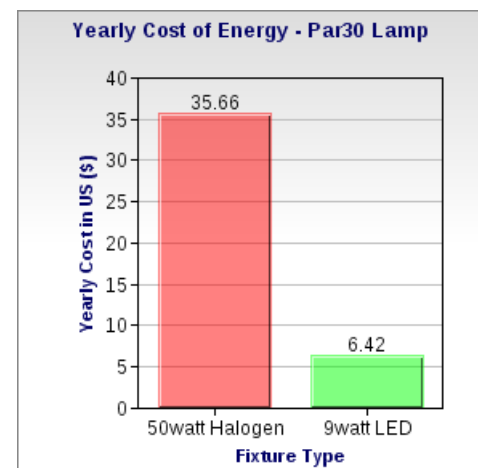

Graph compares the cost of energy per lamp, based on a Commercial price per kilowatt of \$0.1633/hour, 12 hours per day of usage, for 364 days. Cost of energy data for CA from U.S. Department of Energy data for May 2010.